



Strategies for Utilizing Whole Algae Biomass



Fourth Algae World Asia
15-16 November 2011 - Beijing

A BREAKTHROUGH TECHNOLOGY TO EXTRACT OIL FROM ALGAE

Safe Harbor Statement



Matters discussed in this presentation contain forward-looking statements within the meaning of the Private Securities Litigation Reform Act of 1995. When used in this press release, the words "anticipate," "believe," "estimate," "may," "intend," "expect" and similar expressions identify such forward-looking statements. Actual results, performance or achievements could differ materially from those contemplated, expressed or implied by the forward-looking statements contained herein, and while expected, there is no guarantee that we will attain the aforementioned anticipated developmental milestones. These forward-looking statements are based largely on the expectations of the Company and are subject to a number of risks and uncertainties. These include, but are not limited to, risks and uncertainties associated with: the impact of economic, competitive and other factors affecting the Company and its operations, markets, product, and distributor performance, the impact on the national and local economies resulting from terrorist actions, and U.S. actions subsequently; and other factors detailed in reports filed by the Company.

Algae – Its Strategic Use

- q Ancient History
 - q Algae compressed & fossilized into petroleum.
 - q Nature processed the whole biomass – did not separate the oils.
- q Today's Strategy
 - q Lipids and biomass are being separated.
 - q But are they utilized most efficiently?
 - q Algae success is dependent on that efficiency.
 - q What is the most efficient modality?
- q Tomorrow's Strategy
 - q Use whole biomass to create most cost-effective products.
 - q Use extracted oil for high-value products.
 - q Strategy must encompass the full spectrum of Biofuels — Biochemicals — Bionutrients — Food.

Algae – The New Trend

- q Algae Production for End Products Really Divides Into:
 - q Energy products and biochemicals.
 - q Bionutrients and food grade feedstocks.
- q Energy Products and Biochemicals
 - q Require the whole biomass production to be most efficient.
 - q Oil and biomass do not need to be separated.
 - q Multiple downstream processes can handle the whole biomass.
- q Bionutrients and Food Grade Feedstocks
 - q Require that lipids are separated from the biomass and free of chemicals.
 - q The lipids can then be processed into valuable fractions.

**End Uses Determine Feedstock
Requirements**

Dark-Cycle Production for Food-Grade Algae



q Benefits

- q Well proven technology by companies like: Martek & Solazyme.
- q Perfect for nutritional uses:
 - § Nutraceuticals — Pharmaceuticals — Animal Feed — Food — Fertilizer
- q High purity of dark-cycle algae – can even be organic!
- q Solazyme is shooting for \$60-80 production cost Barrel Oil Equivalent (BOE).

q Limitations

- q Sustainability issues:
 - § Land & fresh water use to grow sugar or starches.
 - § Reprocess sugar for algae – duplicate processing.
 - § Then use algae to produce fuel (using a fuel to make a fuel!)
- q None of the CO2 or waste abatement benefits.

**Promising for Food Grade Products
but not Fuel and Chemicals.**

Photosynthetic Algae for Fuel & Chemicals



q Benefits

- q High growth source of biomass for fuel.
- q Higher energy content than other biofuels (up to 100 times greater than corn).
- q Does not compete for farm land for food production.
- q Can use waste water, salt water, brackish water or fresh water.
- q Captures CO₂ and recycles carbon for fuels and co-products.
- q Contaminant removal from waste water streams.
- q Extraction of lipids not required.

q Limitations

- q Not a good source of nutritional feedstocks.
- q Using capturing waste products = no food use.

q Can photosynthetic algae produce food grade products?

Yes, but strict growth controls required, and no waste inputs possible.

OriginOil Supervised System: _____

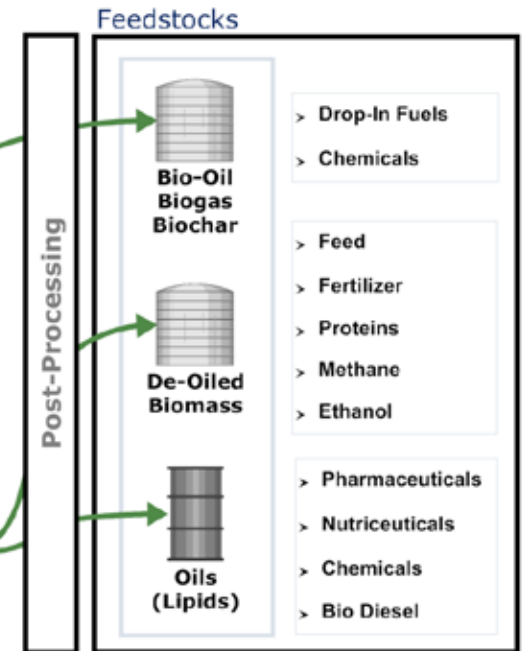
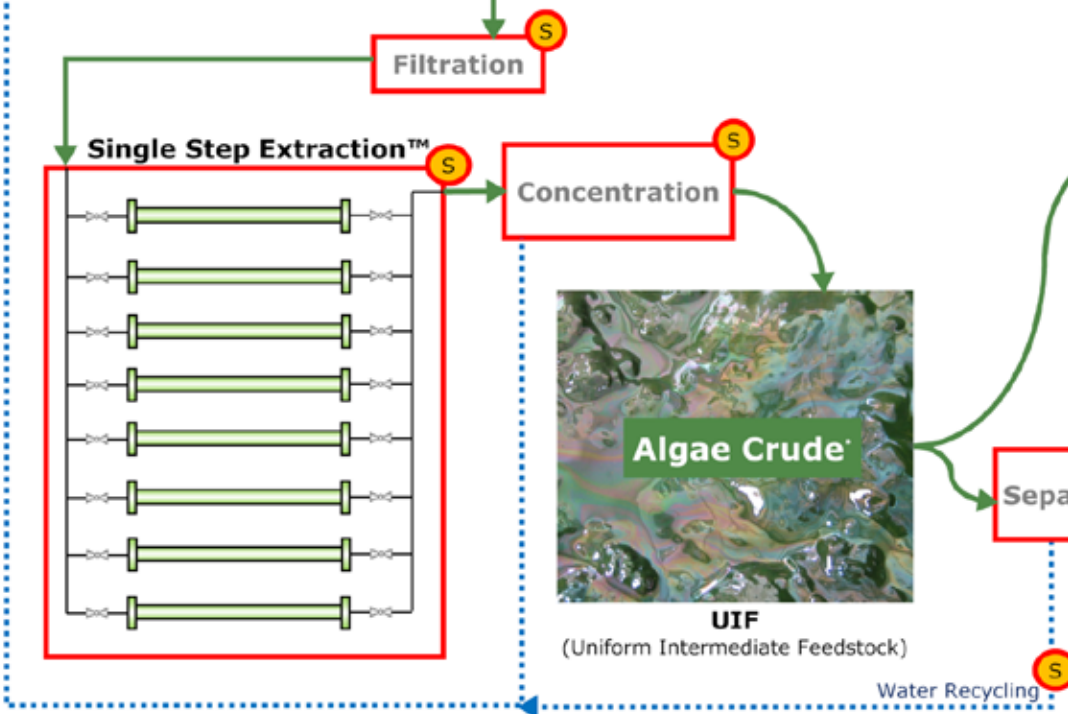
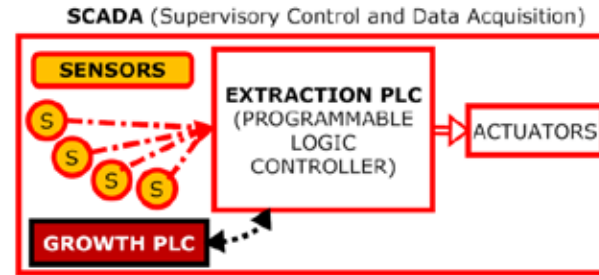
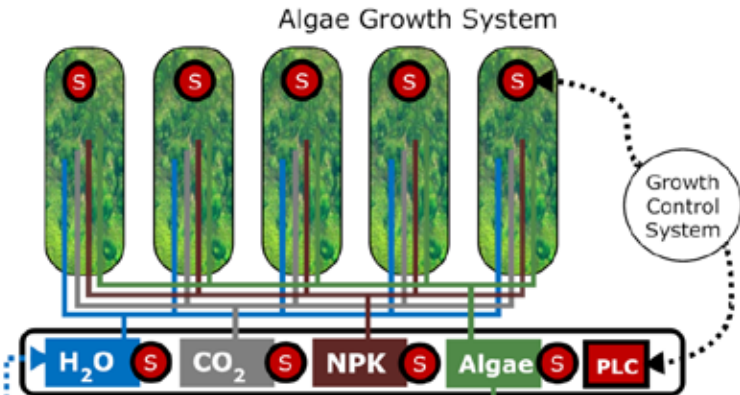

Photosynthetic Algae for Fuel

- q Lipid Extraction For Fuel (biodiesel)? Likely not economical.
 - q Cost of separation is very high.
 - q Algae lipids are high in polyunsaturated fats
 - q Must be made into esters adding to the cost
 - q Then still must be blended.
 - q Other uses for lipids are more valuable (Omega3s, etc.).
 - q Biodiesel is not a drop-in fuel.
- q Most efficient fuel output? Whole biomass.
 - q Algae separation not required.
 - q All of the BTU value of algae is preserved.
 - q Standard refining processes supported.

**Whole Biomass Processing Compares
Closely to Petroleum Processing.**

Photosynthetic Algae for Fuel

- q The Strategic Goal is Drop-In Fuels
 - q Utilizes the existing fuel and chemical infrastructure.
 - q Requires a petroleum-equivalent BIOCRUDE.
- q BioCrude - The Best and Most Efficient Route
 - q Flocculate the biomass – “cracking” the cells improves processing.
 - q Dewater to a pumpable slurry – 10% solids.
 - q Delivers a Uniform Intermediate Feedstock – a precursor to Bio-oil.
 - q Pyrolize/Hydrotreat for Bio-oil.
 - q De-oxygenate for refinable BioCrude feedstock.
 - q Normal petroleum refinery processes.
 - q Create the “Products of Petroleum”
 - ...Including many high value products such as bioplastics.
- q Uniform Intermediate Feedstock > Bio-Oil > BioCrude

Products of Petroleum

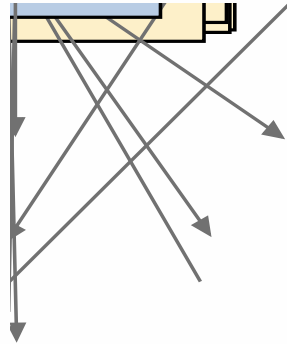

A BREAKTHROUGH TECHNOLOGY TO EXTRACT OIL FROM ALGAE

Uniform-Format Feedstock System

Part of DOE's Biomass Program



- q Specifications are necessary for biomass – just as for petroleum products.
- q High DOE priority on developing standard specifications.
- q Uniform Intermediate Feedstock (UIF) is integrated into DOE's Uniform-Format Solid Feedstock Supply System which blends all types of biomass.
- q Algae UIF, with highest BTU value, is “glue” for other Uniform-Format Feedstock.
- q UIF standard enables upstream producers & downstream processors the ability to standardize.
 - q Results in efficiencies in the supply chain.
 - q More secure investment environment for project development.
 - q Faster industry growth.

DOE's Uniform-Format Feedstock

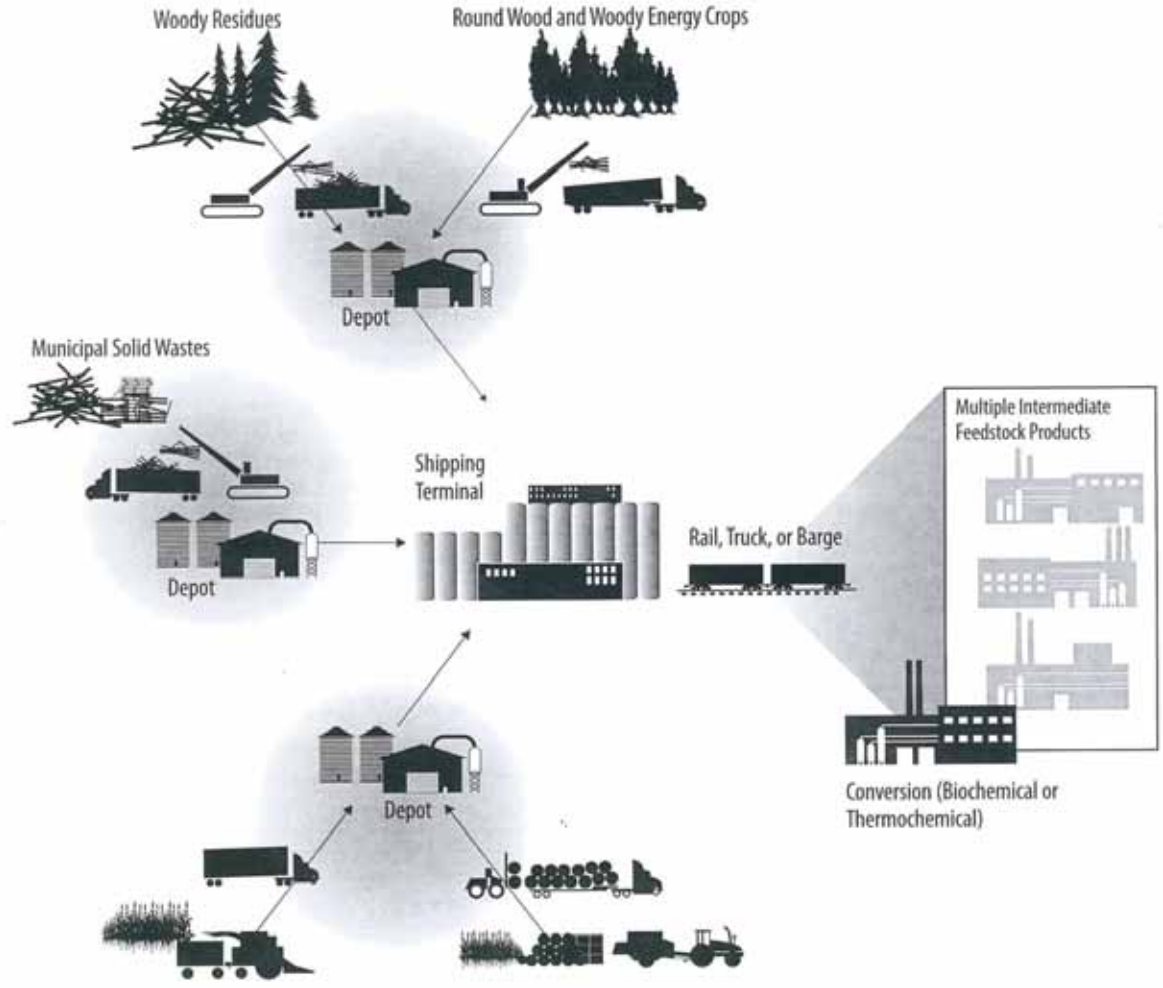

A BREAKTHROUGH TECHNOLOGY TO EXTRACT OIL FROM ALGAE

The Most Effective Way To Create Bio-Oil?



- q Use Single Step Extraction System™, with integrated Concentration
- q Benefits:
 - q No initial dewatering required.
 - q Extremely low energy usage.
 - q No chemicals.
 - q Tunable to a wide range of feedstock.
 - q Small footprint.
 - q Easy installation.
 - q Applicable to all growth platforms.
 - q Fast throughput – highly scalable.
 - q Greatly-reduced Capital Expenditure.
- q Concentration options: Dissolved Air Flotation (DAF), Centrifugation, etc.
- q Product: Uniform Intermediate Feedstock (UIF).

A BREAKTHROUGH TECHNOLOGY TO EXTRACT OIL FROM ALGAE

Algae Appliance™ – A Need Fulfilled



- q OriginOil now building systems to serve one full hectare of production.
This scale is still extremely rare in the algae industry!
- q Next step: create an entry-level system for the algae industry.
- q Announcing the new Algae Appliance, available soon for field testing by select reference accounts.
 - q Standardized starter system so producers, researchers and equipment suppliers can start working with next-generation harvesting technology.
 - q This standardized system is based on the successful research scale system in operation since 2010 at MBD Energy's James Cook University research site.
- q Field test partners benefit from a substantial discount, asked to help OriginOil refine the Appliance.

Algae Appliance Features



- q Flexible Flow Rates:
 - q Minimum: 2 LPM (0.5 GPM) – processing 3000 liters per day in continuous harvest.
 - q Maximum: 20 LPM (5 GPM) – processing 30000 liters per day in continuous harvest.
- q Wide flexibility of microalgae concentration
 - q From 125mg to 1g/liter dry weight – and beyond.
- q Three-phase Operation:
 - q First phase: low-energy, chemical-free flocculation.
 - q Second phase: concentration to remove up to 90 of the water*, which is recycled.
 - q Third phase: cell wall compromise (“cracking”) for downstream availability.
 - q Optional devices available for greater concentration.
- q Sensor telemetry with touch screen software for real-time control.
- q Remote support by OriginOil technicians (requires support contract).

* Concentration is done using a built-in Dissolved Air Flotation (DAF) unit.

A BREAKTHROUGH TECHNOLOGY TO EXTRACT OIL FROM ALGAE

Algae Appliance Front View

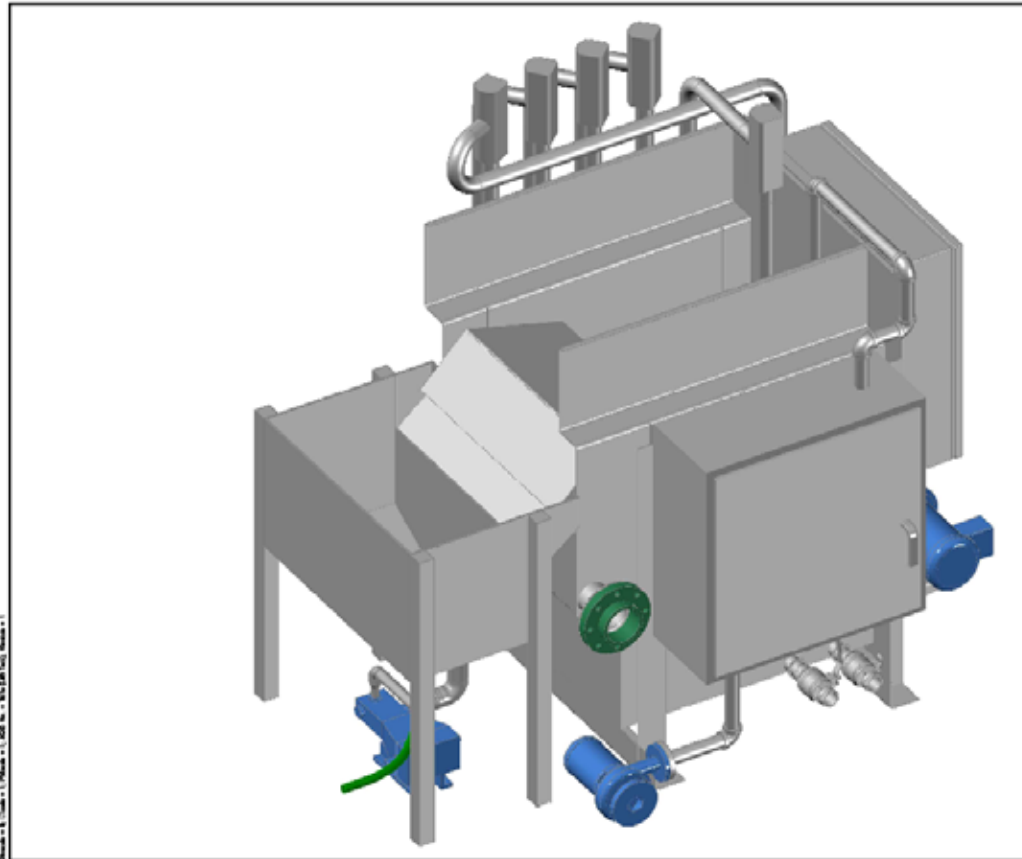

A BREAKTHROUGH TECHNOLOGY TO EXTRACT OIL FROM ALGAE

Algae Appliance Rear View

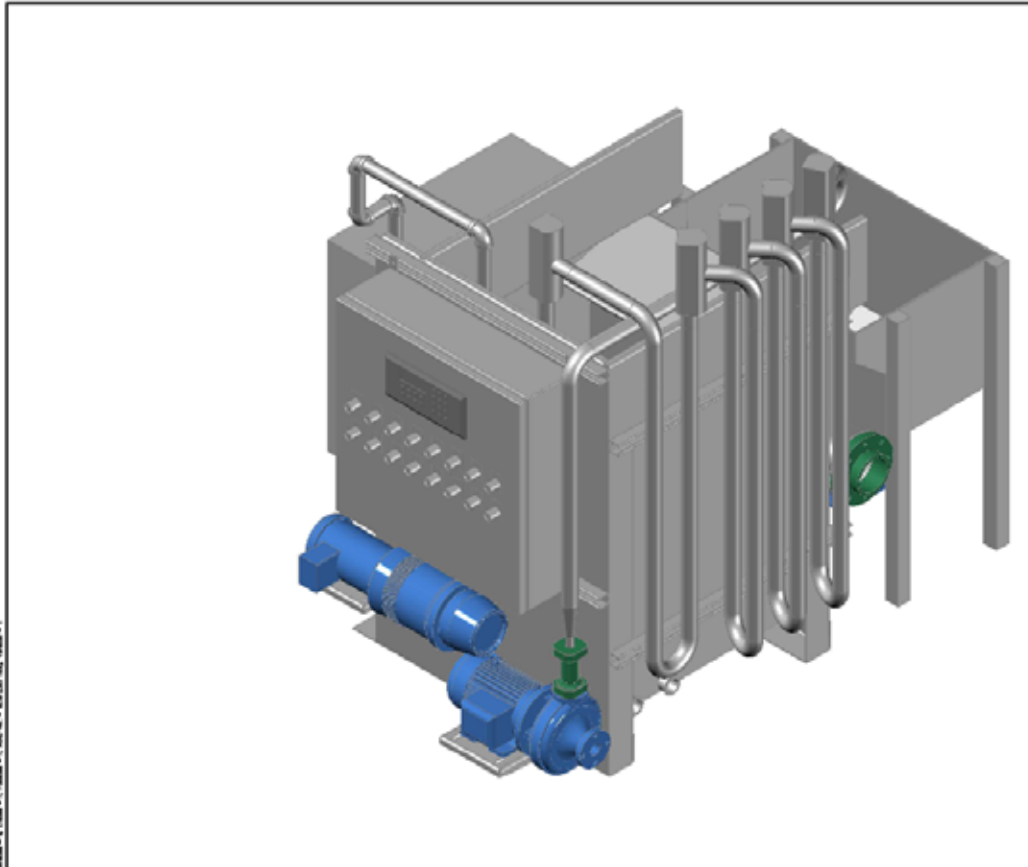

A BREAKTHROUGH TECHNOLOGY TO EXTRACT OIL FROM ALGAE

Algae Appliance Summary



- q What does the Algae Appliance Accomplish?
 - q Entry-level harvester for early process development efforts.
 - q Dewateres 2 to 20 liters/minute of algae slurry.
 - q Concentrates biomass by removing 90 to 95% of the water.
 - q Very low energy footprint – 0.002 kwh at 10 LPM (estimated).
 - q Uses no toxic chemicals.
 - q Compatible with OriginOil's pre-harvest growth treatments.
 - q Achieves a UIF (Uniform Intermediate Feedstock) – a precursor to Bio-oil.
- q Proven Technology
 - q Research system operating successfully up to 60 liters/minute at MBD Energy's JCU site.
 - q OriginOil has shipped its first commercial 40 liters/minute mobile system to MBD.
 - q OriginOil is building a 1200 liter/minute system for MBD.

A BREAKTHROUGH TECHNOLOGY TO EXTRACT OIL FROM ALGAE

Typical 4-Stage Process to Scale



**JCU Research Facility
(5,000 m²)**



**Tarong Energy Display Plant
(1-Hectare)**



**Pilot Plant
(30-90 Hectare)**

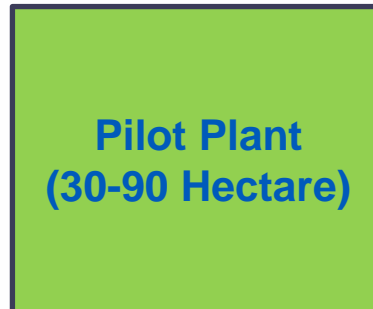

**Demonstration Plant
(500-Hectare +)**



A BREAKTHROUGH TECHNOLOGY TO EXTRACT OIL FROM ALGAE

Summary



- q End use of the algae biomass determines feedstock configuration.
- q Use extracted oil for high-value products – Dark cycle most promising.
- q Use whole biomass for fuel and biochemicals – full Separation not required.
- q Single Step Extraction System achieves UIF, a precursor to Bio-oil.
- q Whole Biomass Post-Processing Compares Closely to Petroleum Processing.
- q DOE's Uniform Format blends multiple feedstocks – algae can be energy booster.
- q The Algae Appliance is an entry-level harvester for early process development efforts.
- q Limited field testing partners invited now.

**Visit www.algaeappliance.com to
Request your Algae Appliance!**



Bill Charneski
Senior Director of Product Engineering

Thank you for your interest.
Do you have any questions?

OriginOil, Inc.
(OTCBB: OOIL)
www.originoil.com
(877) 999-OOIL (6645)